

IT IS THE RESPONSIBILITY OF THE USER ORGANISATION TO PROVIDE THE IDENTITY CARD AND TO FILL IN THE DETAILS REQUIRED.  
 THE IDENTITY CARD SHOULD BE FILLED IN BEFORE THE FIRST USE BY A COMPETENT PERSON, RESPONSIBLE IN THE USER ORGANIZATION FOR PROTECTIVE EQUIPMENT.  
 ANY INFORMATION ABOUT THE EQUIPMENT LIKE PERIODIC INSPECTIONS, REPAIRS, REASONS OF EQUIPMENTS WITHDRAWN FROM USE SHALL BE NOTED INTO THE IDENTITY CARD BY A COMPETENT PERSON.  
 THE IDENTITY CARD SHOULD BE STORED DURING A WHOLE PERIOD OF EQUIPMENT UTILIZATION.  
 DO NOT USE THE EQUIPMENT WITHOUT THE IDENTITY CARD.  
 ALL RECORDS IN THE IDENTITY CARD CAN BE FILLED IN ONLY BY A COMPETENT PERSON.

## IDENTITY CARD

MODEL AND TYPE OF EQUIPMENT	
REF. NUMBER	
SERIAL NUMBER	DATE OF MANUF.
USER NAME	
DATE OF PURCHASE	DATE OF PUTTING INTO OPERATION

### PERIODIC EXAMINATION AND REPAIR HISTORY

	DATE	REASON FOR ENTRY PERIODIC EXAMINATION OR REPAIR	DEFECTS NOTED, REPAIRS CARRIED OUT AND OTHER RELEVANT INFORMATIONS	NAME AND SIGNATURE OF COMPETENT PERSON	PERIODIC EXAMINATION NEXT DUE DATE
1					
2					
3					
4					
5					
6					
7					
8					
9					
10					
11					
12					
13					
14					
15					
16					

PROTEKT, 93-403 LODZ,  
 ul. Starorudzka 9, POLAND

TEL: (48 42) 680 20 83, FAX: (48 42) 680 20 93  
 www.protekt.com.pl



## Instruction manual

Before use, carefully read the following instruction manual

Ref.: AT063

**PROTEKT®**

## PORTABLE ROOF ANCHOR FOR METAL ROOFS

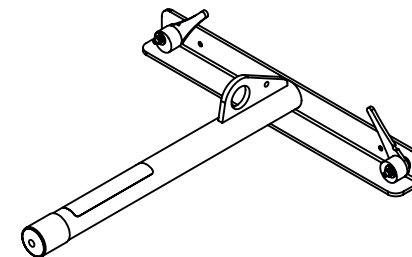

**Warning:** This product is part of a fall protection system. Users must read and follow instructions in this guideline for each component of the complete system. Manufacturer's instructions must be followed for correct care, use and maintenance of this product. Alterations or misuse of this product, or failure to follow instructions may result in serious injury or death. Reading this manual of itself does not constitute competency based training in the use of fall arrest products or systems.

### GENERAL USE WARNINGS

VISUALLY INSPECT TEMPORARY ANCHOR PRIOR TO, AND FOLLOWING EACH USE, TO ENSURE IT IS IN A SERVICEABLE CONDITION (refer to section 5.1). IF IN DOUBT, REMOVE FROM SERVICE IMMEDIATELY. INSTALLATION AND USE OF THIS PORTABLE ROOF ANCHOR MUST BE PERFORMED BY, OR UNDER THE SUPERVISION OF A COMPETENT PERSON.

DO NOT ATTACH OR USE TEMPORARY ROOF ANCHOR WITHOUT FIRST READING, UNDERSTANDING & FOLLOWING THESE INSTRUCTIONS.

DO NOT USE THIS PORTABLE ANCHOR FOR ANY PURPOSE OTHER THAN FOR WHICH IT HAS BEEN DESIGNED. PRIOR TO COMMENCEMENT OF WORK, PLEASE ENSURE THAT YOU HAVE READ AND COMPREHENDED THE DETAIL REFERRING TO POSITIONING OF THE ANCHOR AND THE APPROPRIATE SAFE WORK AREA. THIS TEMPORARY ANCHOR POINT MUST BE SUBJECTED TO A DOCUMENTED INSPECTION EVERY 12 MONTHS BY A COMPETENT PERSON.

### INTRODUCTION

This is a Temporary Anchorage device that has been designed as a component of a personal fall arrest system and is for use only where there are no other practical means of connection or work practice. Relevant State or national legislation may impose obligations to provide safe systems of work. To discharge these responsibilities, could hazard identification and risk assessment with reference to the hierarchy of control risks. Refer to your local State of Federal guidelines or Code of Practice for safe work on roofs for more details.

Anchors must be properly installed prior to the operator attaching to them and then used according to requirements contained in this manual.

### ANCHOR DESIGN AND APPLICATION

The Portable Roof Anchor for Metal Roofs has been designed and tested to 15kN and is therefore rated as a single person fall arrest anchor under AS/NZS1891.4. It is only suitable for use on roofs constructed with metal roof sheeting with a minimum BMT of 0,42 mm in the following profiles - Custom Orb, Trimdek, Spandek and Klip-Lok 406 & Klip-Lok 700 provided ridge-capping is secured in place with roof screws per manufacturer's instructions.

**IMPORTANT:** The Portable Roof Anchor is NOT suitable for tiled, shingled, aluminium sheet, asbestos or decramastic roofs.

**IMPORTANT:** This anchor is designed to be attached to the opposite side of the roof from where you intend to work. Do NOT connect to or use the anchor on the same side of the roof where anchor is connected.

If a second person is required to work on the roof, a second anchor device must be used. Connecting two lines to a single anchorage device is NOT permitted. Where two connecting devices are attached to the same anchorage point (e.g two snap hooks), the snap hooks may rub against each other, causing them to be entangled or even become disengaged from the anchorage device.

Additionally, testing has concluded that whilst this device can sustain a load of 22kN, the roof sheeting profiles most commonly used in Australia and New Zealand will not sustain a static load greater than 15kN.

**IMPORTANT:** Do **NOT** work outside an arc of 30 degrees either side of the centre line of the anchorage location to reduce the danger of swing fall hazards - refer to Figure One over the page.

The user of this Portable Roof Anchor shall be trained and ensure that care is taken to adjust the safety line length so that she/he will not be able to fall off the ends of the roof.

**IMPORTANT:** The Portable Roof Anchor is **NOT** suitable for use as an anchorage device for Temporary Horizontal Life Line.

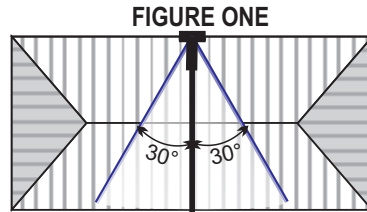

### STRENGTH OF SUPPORTING STRUCTURES

If it is unclear to the operator or competent person that the roof sheeting or structure is adequate, the roof sheeting or structure shall be assessed by an engineer. It is **NOT SAFE** to climb onto the roof on the same side as you have attached the anchor or use it when connected to the same side.

The supporting structure / roof sheeting should be capable of sustaining an ultimate load equal to 15kN for single point connection as per AS/NZS1891.4.

### RECOMMENDATIONS

Employers, Supervisors and Operators should ensure that:

- Location of anchors comply with the requirements for safe use, safe access, the pendulum effect, as stipulated in AS/NZS 1891.4 clause 3.2.
- Structural supports for anchors are assessed separately by a suitably qualified engineer (as stipulated in AS/NZS 1891.4 clause 3.1.2.) or by a competent person, as appropriate, and the assessment documented.
- Anchors are inspected for compliance with the requirements in AS/NZS1891.4 clause 9.3.3 and the inspection documented. The documentation should specify any ongoing requirement to carry out testing of anchor points.
- Anchors are properly labelled and instructions for safe use and appropriate installation plans are supplied to the user.
- ALL operators must be competently trained for safe work at height prior to commencing any activities as per AS/NZS 1891.4.

### ASSESSING FALL HAZARDS

Employers must ensure that any task an employee is required to undertake on a roof, that any potential fall hazard is identified, such as:

- from an unprotected edge;
- from an unsecured or inappropriately fixed ladder or scaffold;
- slipping on a wet or steep pitched roof (caused by inclement weather or inappropriate footwear);
- accessing varying roof levels;
- through a fragile roof;
- through a ceiling, skylight or vent;
- being blown or knocked over the edge of a roof.

All such hazards should be identified in the risk assessment process and documented with relevant precautions to be taken to avoid personal injury in advance of any work taking place.

### SWING FALL

Operators should ensure they do not subject themselves to a common hazard known as swing fall, refer to Figure Two.

Precautions to avoid this hazard include removing working slack from the rope working line, using restraint techniques and ensuring the person does not approach a leading edge such they may be subjected to an unplanned fall.

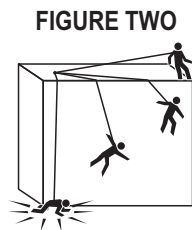

**FIGURE EIGHT B**

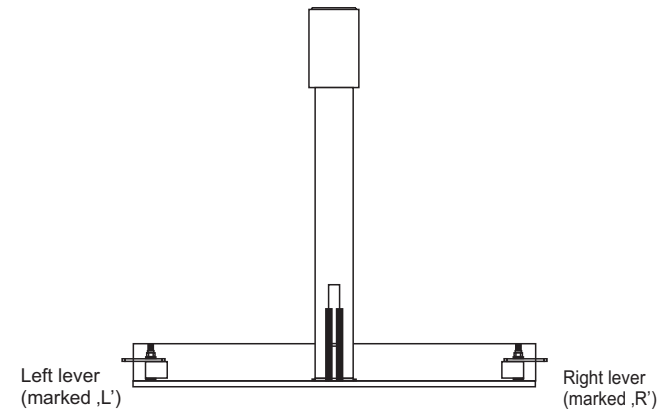

### GENERAL PRINCIPLES OF USING THE EQUIPMENT

- The equipment should be used only by people trained in its use.
- Personal protective equipment may not be used by people whose health condition may affect the general safety during daily use.
- It is prohibited to perform any modifications to the equipment without the manufacturer's written consent.
- Any repair can be performed only by the equipment manufacturer or its authorized representative.
- It is forbidden to use the equipment for purposes other than its intended use.
- Before use, make sure that all components of the equipment work together properly. Periodically check that all of the device's components are in place,
- During inspection, check all components of the equipment with particular attention to any damage, excessive wear, corrosion, abrasion, cuts, and malfunction. In each device pay special attention to:
  - cracks in welds;
  - missing components.
- During periodic inspections, check the legibility of all labelling of the protective equipment (mark of the given device).
- If there is any doubt as to the condition of the equipment or its operation, immediately withdraw it from use. The equipment may be readmitted for use after a thorough inspection by the manufacturer of the equipment and the manufacturer's written consent for further use of the equipment.
- When using the equipment pay special attention to dangerous phenomena affecting the operation of the equipment and user's safety, in particular:
  - looping and moving of the rope over sharp edges;
  - oscillatory falls;
  - any damage, such as cuts, abrasion, corrosion;
  - the impact of extreme temperatures;
  - the negative impact of weather conditions;
  - the impact of chemicals.
- The equipment must be transported in containers that protect it from damage or getting wet, e.g. in bags made of impregnated fabric or in steel or plastic suitcases or boxes,
- The equipment must be cleaned and disinfected, avoiding damage to the material (raw material) from which the device is made. For textile materials (tape, rope), use cleaning agents dedicated to delicate fabrics. It can be cleaned by hand or washing machine. Rinse thoroughly. Plastic parts must be cleaned only with water. The equipment that gets wet when cleaning or during the use must be thoroughly dried in natural conditions, away from the sources of heat. Metal parts and mechanisms (springs, hinges, latches, etc.) can be lightly lubricated periodically in order to improve their performance.
- The equipment must be stored loosely wrapped in a well ventilated dry place, protected from light, UV radiation, dust, sharp objects, extreme temperatures and corrosive substances.

Before and after each use of the AT063, carefully inspect it to ensure it is in serviceable condition. Check for worn or damaged parts. Inspect for sharp edges, burrs, cracks or corrosion. Inspect all other fall protection equipment used along with this system in accordance to within the inspection period. If in doubt, do not use the equipment and refer to a competent person for inspection and certification.

**TRAINING IN THE USE OF FALL ARREST SYSTEMS**

The use of this product must be accompanied by competency based training in fall arrest systems - reading this manual alone will not be sufficient for all people - particularly those with no training in fall protection equipment or with prior experience at working at height. The training and instruction given should cover at least:

- How to complete a risk assessment of a work area and prepare work instructions and work method statements to be put into place for a safer working environment;
- The method to be used in carrying out the specified work task. this should include access and the attachment method;
- The correct use, care and storage of individual fall arrest equipment and temporary fall arrest systems;
- Inspection and maintenance of fall arrest equipment and recording information on a log card;
- The procedure to be adopted in the event of an accident or injury (i.e. rescue and recovery).

**SUPERVISION OF THE USE OF FALL ARREST SYSTEMS**

The employer must ensure that:

- Only employees who have received training and instruction in relation to the system of work are authorised to carry out the work;
- That adequate occupational safety and health systems are in place and functional and that safe work practices have been adopted and are used. This should include the use of fall arrest systems and devices.

**ANCHOR SCHEMATIC DRAWINGS**

**FIGURE EIGHT A**

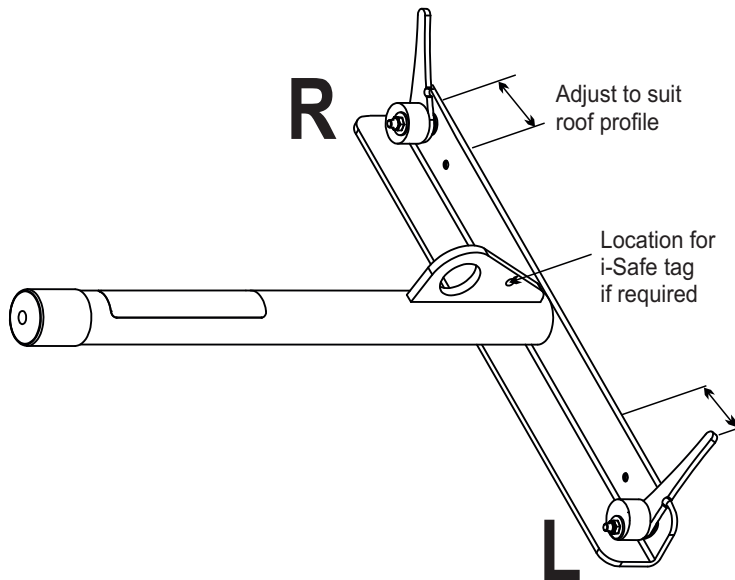

Warning: Levers are separately marked "L" and "R" Ensure anchor cam levers are re-installed in the correct location and locked down to ensure safe connection.

**INSTALLATION**

**Installing AT063 on the roof**

**Step 1:** Plan and prepare for the work to be undertaken. Complete a risk analysis of the site to determine all the potential hazards. Consideration should be given to work method statements, safe access, roof structure/sheeting integrity, rescue procedure and so on.

**Step 2:** Inspect all equipment (AT063, Harness and any associated Safety Equipment) prior to use to ensure it is within operating period and is fit for purpose, free of damage etc. This process should include a thorough inspection of structure to which the AT063 will be installed. Refer to section 5.1 for inspection, care and maintenance details.

**Step 3:** A safe means to access the intended temporary anchor installation shall be provided.

Access to the roof will generally be by scaffold or ladder systems. Scaffolding may only be erected, moved or disassembled by a competent person and fall protection principles must be followed in those processes. Further information can be obtained from AS/NZS 4576 Guidelines for Scaffolding.

Where access is by ladder systems, the following items should be checked:

- Inspect the ladder rungs and rails for any defects, cracks or corrosion.
- Never use a ladder with split or missing rungs or with oil or other slippery material on the rungs.
- The ladder should be fitted with non slip feet.
- Place the ladder at a slope of 4 to 1, and secure both hands free to hold the ladder.
- Ascend and descend facing the ladder with both hands free to hold the ladder.
- Always keep the area near the top and bottom of the ladder clear.
- Ladder side rails must extend 1m above the landing surface and be secured at the top to prevent slipping.

Further information can be obtained from AS/NZS 1892.1 Portable Ladders Part 5: Selection, Safe Use and Care.

Safely position a portable ladder close to the roof location where the temporary anchor is to be located. Ensure the ladder is securely fastened to the building to remove the risk of a fall from the ladder - refer to Figure Three.

**FIGURE THREE**

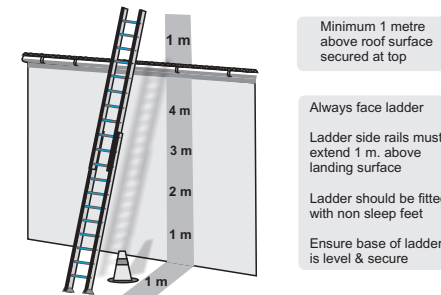

**WARNING:** If it is unclear to the operator or competent person that the supporting structure, roof sheeting or anchor is structurally inadequate, they must be assessed by an engineer.

**Step 4:** Once you have safely ascended the ladder, slide the bottom angle iron of the portable roof anchor under the roof sheeting. The cylindrical support must rest in the pan of the roof sheeting. Both locking cam levers must also be located within the roof sheeting pans. If they do not fit within the pan, reposition the locking cams into an alternative adjustment position along the L-angle until they do.

**NOTE:** When adjusting the position of the locking levers, ensure left and right levers are correctly installed. Refer to section 6, Figure Eight a & b for correct orientation.

**FIGURE FOUR**

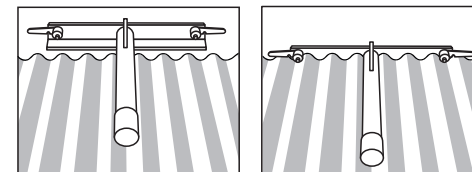

**Step 5:** Securely push down locking cam levers onto roof sheeting to achieve a solid connection. Once the anchor is attached and your anchorage line is secured to the anchor point, throw the rope over to the other side of the roof such that the anchor line is accessible without climbing onto the roof, Refer to Figure Five.

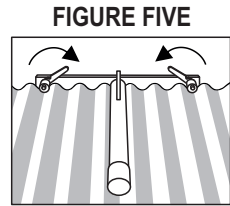

**Step 6:** Return to the ground and walk to the other side of the roof and connect to rope grab on the anchorage line to the fall arrest connection point on your full body harness. Capital Safety always recommends that a shock absorber be used between the rope grab and the connection point to reduce the risk of injury in a fall.

**NOTE:** A second AT063 device can be installed on the opposite side of the roof to enable the operator to work both sides of the roof and be connected between them with two separate rope lines. This is called Restraint Technique.

### REMOVAL AT063

After descending the roof from the access side and disconnecting from the anchor line, then climb the ladder you have placed (safely) close to the temporarily installed anchor and simply reverse the process used installation.

### PROVISION OF PPE

Before commencing work on roofs, the contractors doing the work should assess all foreseeable conditions likely to affect the health and safety of the employees or themselves, as identified during the risk assessment procedure, and arrange for the provision and use of appropriate Personal Protective Equipment (PPE). If alternative means of access can be arranged safely without the need of PPE, these methods should be adopted first if deemed practical.

### TYPES OF PPE

The following are examples of PPE often associated with roof work, Appropriate PPE, whether listed below or not, should be provided when required:

- Fall arrest equipment should be selected to protect the wearer and allow them access to the areas they need to work, maintaining freedom of movement and be comfortable;
- Footwear to reduce the risk of falls resulting from slips - rubber soled shoes with herring bone or similar nonslip tread pattern are commonly selected;
- Eye protection to reduce the risk of eye injury - eye protection complying with AS1337 Eye protectors for industrial applications should be provided and used;
- Protection from sun, workers should be protected from sunlight/UV radiation by using a sunscreen with a sun protector factor (SPF) rating of at least 30+ and by wearing hats, shirts with long sleeves and long trousers.

### USING THE AT063 WITH FALL ARREST EQUIPMENT

The anchor should be fitted in accordance with the manufacturer's instructions (Section 2.0) at the edge of the non working side of the roof.

**Step 1:** The operator should inspect and don a fall arrest rated harness fitted with a frontal fall arrest point and adjust it to ensure it is correctly fitted and comfortable There is recommendation that a shock absorber be used between the rope grab and the connection point to reduce risk of injury in a fall. The rear (dorsal) fall arrest connection point also deemed an **appropriate connection point however its selection/use will depend on the type of work being completed.**

**Step 2:** Once the AT063 is installed as per instructions in Section 2.0, ensure the rope is of sufficient length to hang two meters past the proposed connection point on the alternative side of the roof in order to facilitate attachment to a fall arrest attachment point prior to leaving the ladder or scaffold. The rope should be pulled tight and tensioned to ensure all slack has been taken up before connection, If the rope grab is already on the rope, ensure it is positioned at the free end.

**Step 3:** The roof should then be accessed from the working side, the operator connecting the rope grab to the rope (or accessing the rope grab permanently attached to the rope) and the shock absorber to the rope grab before moving from the ladder or scaffold onto the roof.

**Step 4:** To minimise the fall distance resulting from any slip or fall, it is important to have the least amount of slack on the line at any point in time. This means regular and small adjustments of the grab up and down the rope in line with the required movement on the roof. Refer to Figure Six over the page.

When moving up the roof, the manual rope grab should be opened and slid up the rope as much as an arm's length. It should immediately be released to lock the rope grab onto the rope. The worker should climb towards the rope grab and repeat the movement until the work position has been reached.

When moving down the roof, the worker should move down until the rope is taught, then release and move the rope grab towards the body, releasing it to again provide an anchor. When the work position has been reached, the rope grab should be released and run up the rope toward the roof ridge to remove as much slack as possible.

By removing the working slack from the system, the person reduces the risk of swing fall, lessens overall fall distance and reduces possible fall distance in the event the roof surface gives way, allowing the person to fall through.

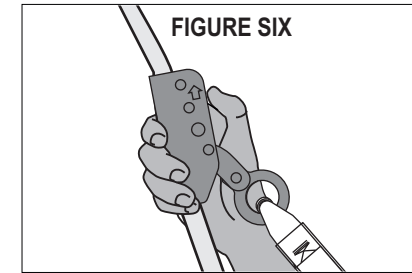

### GENERAL OPERATIONAL WARNING - SAFE WORK AREA

When traversing the roof, the same procedure should be followed and should be set up such that the system operator will be prevented from reaching an unprotected edge.

The operator of the AT063 Portable Roof Anchor shall be trained and ensure that care is taken to adjust the safety line length so that he/she will not be able to fall off the ends of the roof.

The maximum number of operators connected at the a time shall not exceed one.

Do not climb onto the same side of roof that the anchor is installed on. If work is required on both sides of the roof, install two separate The AT063 anchors and rope lines on opposite sides.

The AT063 Portable Roof Anchor should never be installed on the ridge line or ridge capping of a roof.

Do not work outside an arc of 30 degrees either side of the centre line on the AT063 to reduce the danger of swing fall hazards. Always work a minimum of 2 m from unprotected edge (refer to Figure Seven).

FIGURE SEVEN

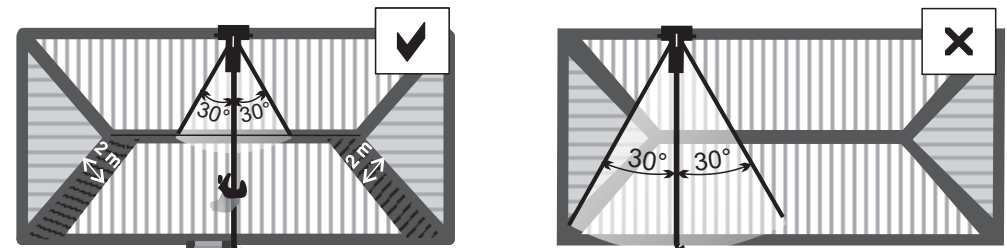

### STANDARDS COMPLIANCE

The AT063 has been manufactured in accordance with AS/NZS 1891.4 and meets its requirements when used in accordance with the operator's manual.

### INSPECTION, CARE AND MAINTENANCE

Before first use, ensure product identification details have been recorded in this manual and that it is stored safely for future reference, along with the recording of annual inspections by a competent person. Alternatively, store the records of inspections number attached to the individual components purchased. The instruction label on the AT063 also has room for recording inspection dates if required. Alternatively, an i-Safe™ tag can be retrofitted to the device to assist with product identification.