

A



PROTEKT

 CE 0082 EN353-2:2002
 + PPE-R/11.075

 EN Guided type fall arrester with anchor line
LINOSTOPII ED
 Ref. AC061ED

 ed. 1 / 30-09-2024 PP
 0001973

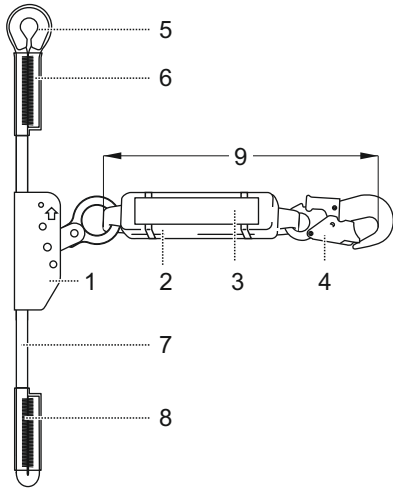
B



C

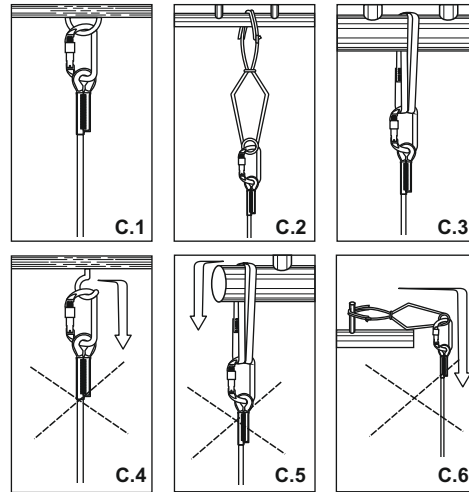

D

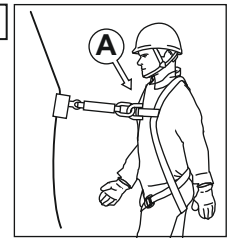

E

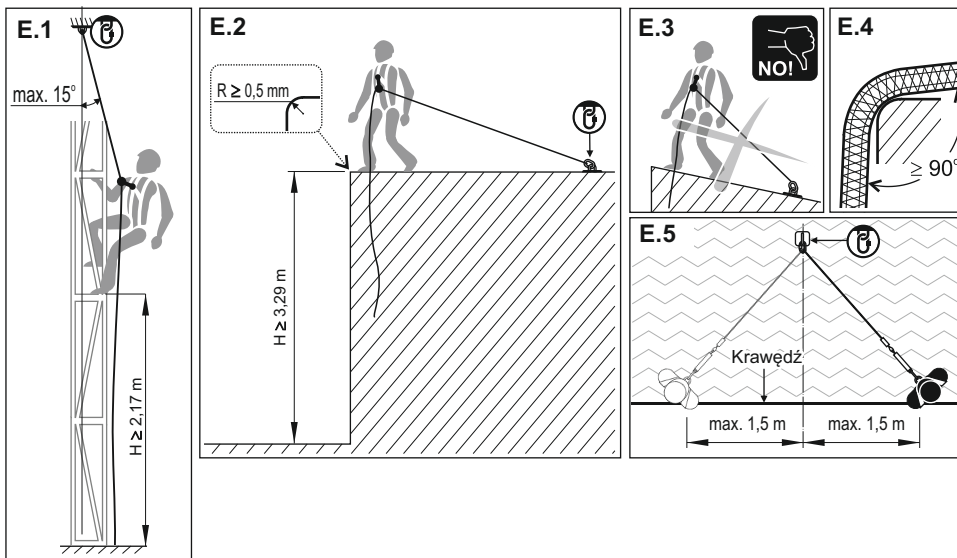

F

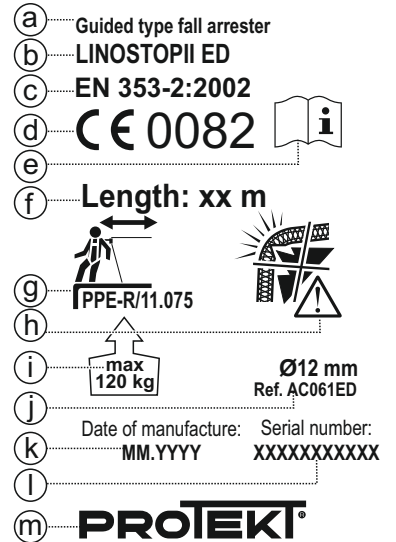

EN – ATTENTION: Read and understand this user manual before using this equipment. Work requiring the use of this equipment is dangerous. The user is obliged to follow this manual and is responsible for the correct use of the equipment. Misuse of the equipment can lead to injury or death. If you have any problems understanding this manual, please contact the equipment manufacturer.

A. DESCRIPTION. The LINOSTOPII ED guided type fall arrester with flexible guide is a component of personal protective equipment against falls from a height. The equipment is compliant with EN 353-2. The equipment uses a polyester anchor line (working line) with a diameter of 12 mm. The LINOSTOPII ED device is a ready-to-use component of personal protective equipment. The line mechanism is permanently attached to the working line and cannot be removed from the line under any circumstances. The LINOSTOPII ED device is designed to protect one worker with a maximum weight of 120 kg. The LINOSTOPII ED guided type fall arrester has been successfully tested in accordance with PPE-R/11.075 (which is not covered by CE marking regulations) for use horizontally when a fall over an edge may occur. During testing, a steel profile with a radius of $r=0.5$ mm was used, with no sharp edges or burrs. This testing has proved that the equipment is suitable for use on similar edges, e.g. rolled steel profiles, wooden beams or rounded roof parapets. The device comes in different lengths, from 5 m to 100 m.

B. COMPONENTS. 1. Steel travelling grip device; 2. Energy absorber made of polyester; 3. Feature of the device; 4. Connector of the energy absorber; 5. The upper end of a work line fitted with a thimble; 6. Working line feature; 7. 12 mm diameter polyester core working line; 8. Lower end of the working line in the form of a safety loop; 9. Maximum permissible length of shock absorber with the connector = 32 cm.

C. FIXING THE WORKING LINE TO A STRUCTURAL ANCHOR POINT The anchor line (working line) must be fixed to a structural anchor point using a connector or anchoring device complying with EN 362 (C.1 and C.2) or EN 795 (C.3). The static strength of the structural anchor point must be at least 12 kN. The shape and design of the structural anchor point must protect against the spontaneous disengagement of the device (C.4, C.5, C.6). The use of certified and approved anchor points complying with EN 795 is recommended.

D. CONNECTING THE TRAVELLING GRIP DEVICE TO THE FULL BODY HARNESS. The connector of the device must be connected to the attachment point of the full body harness, marked with a capital 'A'. The use of a front attachment point is recommended. The full body harness must comply with EN361.

E. KEY PRINCIPLES WHEN WORKING WITH THE LINOSTOP DEVICE II ED. E.1 Ensure safe fall arrester action by providing a minimum required free space 'H' of at least 2.17 m below the user. When working with an anchor line in excess of 20 m, the free space below the user must be increased by 5% of the device length. If the anchor line is fixed to an anchor point located directly above the position of the user, the maximum permissible bending angle of this anchor line with respect to the vertical is 15° relative to the line of the structural anchor point during the user's sideways movement. E.2 The device has been tested in accordance with the requirements of PPE-R/11.075. The scope of application covers works involving the user moving horizontally on sites that present a risk of falling over the edge (e.g. on flat roofs). The minimum edge radius must be 0.5 mm. If the edge is sharp or poses a high risk of damage to the line, e.g. there are burrs on its surface, install suitable edge protection. The minimum free space ensuring safe fall arrest, calculated from the edge through which a fall may occur, must be 3.29 m. E.3 The anchor line (working line) is not located below user's feet's level. E.4 Ensure the

bending angle of the anchor line on the edge when the line is to stop a fall is at least 90° . E.5 When working with the guided type fall arrester, ensure you handle the anchor line so that it is not too loose. The user can adjust the length of the fall arrester (by sliding the travelling grip device over the anchor line) only when the user is not moving towards the edge that he/she can fall over. To avoid the risk of the 'pendulum effect' during a fall, ensure that you move no farther than 1.5 m horizontally with respect to the vertical axis of the anchor point, in either direction. If this is not the case, an anchoring device complying with EN795 Type C or Type D should be used instead of a structural anchor point. When a horizontal anchor line complying with EN 795 Type C is used, its possible deflection should be taken into account, which will affect the amount of free space "H" below the workstation. Read and consider all information contained in the instructions manuals of horizontal anchor lines. When the equipment is stopping a fall over the edge, the user can sustain injuries from impact against parts of the building or other structures. Ensure you prepare and practise special rescue procedures in case of such occurrences. NOTE: When climbing and lowering in the first 2 metres above ground level, the user may not be properly protected from collision with the ground during a fall, so extreme caution is required when working at such heights.

F. DESCRIPTION OF MARKINGS. a) type of device; b) model; c) number and year of issue of the European standards applicable to the device; d) CE marking and number of the notified body supervising the manufacturing process; e) read the instructions for use carefully before use; f) length of the anchor line (work line); g) approved for horizontal use/to prevent falling over the edge as required by PPE-R/11.075; h) anchor line (work line) shall not be stressed on sharp edges; i) maximum rated load; j) diameter and part number of the anchor line (work line) to be used with the LINOSTOPII ED guided type fall arrester; k) month and year of manufacture; l) serial number of the guided type fall arrester; m) manufacturer's designation

G. SCHEDULED INSPECTION The equipment is subject to scheduled maintenance inspections every 12 months from the date of first use. The scheduled inspections must be carried out by a qualified professional only, with knowledge and skills required to carry out scheduled inspections of PPE. Depending on the type of work and working site environment, the equipment may need maintenance work more frequently than every 12 months. After 5 years of use, we recommend a periodic inspection by a company or person authorised by the device manufacturer. Ensure you record each scheduled inspection in the equipment's operation sheet.

H. MAXIMUM SERVICE LIFE OF THE EQUIPMENT The maximum service life of the appliance is 10 years from the date of manufacture.

H. WITHDRAWAL FROM USE The equipment must be taken out of service and subsequently disposed of immediately after it arrested a fall or it is found to be unfit for further use on the basis of an inspection or if any doubts as to its good working condition arise.

NOTE: The maximum service life of the equipment depends on the intensity of use and environmental conditions. Using the equipment in harsh conditions, marine environment, on sharp edges, when exposed to high temperatures or aggressive substances, etc., can mean that the equipment must be withdrawn from use even after one use.

I. ESSENTIAL RULES FOR THE USERS OF PERSONAL PROTECTIVE EQUIPMENT AGAINST FALLS FROM A HEIGHT

The PPE may only be used by people who are trained and competent in maintaining safety.
 The PPE must not be used by persons whose health condition could pose an additional risk to their own safety during normal use and rescue operations.

A separate emergency action plan must be drawn up for each working site with possible hazards taken into account.

When being suspended on a PPE (e.g. after it arrests a fall), look out for suspension trauma symptoms.

To prevent the suspension trauma symptoms, make sure you can follow a relevant emergency action plan. The use of relief step straps is recommended.

The structure of the equipment may not be altered in any way without a prior written consent of the manufacturer.

All repairs may only be carried out by the manufacturer of the equipment or people authorised by it.

You are prohibited to use the PPE beyond its performance specification or for purposes other than its intended use.

One piece of PPE must be assigned to only one user.

Prior to every use, check all the components fitted in the connecting and shock absorber units for compliance. During use, regularly check the connection and adjustment of the equipment components to prevent them from being accidentally loosened or disengaged.

It is prohibited to combine the equipment components where the safe operation of one component affects or interferes with the safe operation of another.

Before each use of PPE, it is mandatory to carry out an initial check of the equipment for proper operation to ensure that its condition enables its safe use.

When carrying out the initial check of the equipment, examine all components for damage, excessive wear, corrosion, abrasions, cuts or malfunctions, and particularly: - for harnesses and belts – buckles, adjusting devices, attachment points, straps, stitching, loops; – for energy absorbers – attachment loops, straps, stitching, casing, snap hooks; – for textile lanyards, safety lanyards or belaying lanyards – lanyard, loops, thimbles, snaps, strands; – for wire lanyards, safety lanyards or belaying lanyards – lanyard, strands, clips, ferrules, loops, thimbles, snap hooks, adjusting devices; – for retractable type fall arresters – lanyard or strap, correct operation of deployment mechanism and brake, housing, energy absorbers, snap hook; – for guided self-locking devices – body of retractable type fall arresters, operation of sliding mechanism, operation of locking mechanism, rivets and bolts, snap hook, energy absorbers; – in metal components (connectors, hooks, anchor points) – main body, rivets, latch, operation of locking mechanism.

Following each 12-month period of use, the PPE must be taken out of service for a scheduled maintenance inspection. The scheduled inspections must be carried out by a qualified professional only, with knowledge and skills required to carry out scheduled inspections of PPE. The scheduled inspection may be carried out either by the manufacturer or by its authorised entities.

For certain types of complex equipment, e.g. certain types of retractable type fall arresters, annual examination can only be carried out by the manufacturer or its designated entity.

Regular scheduled maintenance significantly improves the equipment's life, as well as the safety of its users which depends on the performance and durability of the equipment.

When carrying out a scheduled inspection, ensure you check the markings on the equipment for their legibility. Do not use equipment with illegible marking.

If the equipment is to be marketed and/or used in a country other than that in which it was originally intended, the introducing party must provide instructions for use, maintenance, scheduled inspection and repairs written in the language of the country in which the product is to be used.

The PPE must be taken out of service as soon as any doubts arise as to its condition affecting safe use. Such PPE may not be reused until the manufacturer or its authorised entity has confirmed in writing that the equipment has been put through comprehensive testing.

The PPE must be taken out of service and subsequently disposed of immediately after it arrests a fall (or other procedures must be implemented according to the specific instructions in the equipment manual).

The full body harness (as per EN 361) is the only permissible body retaining device that can be used with the connecting and energy absorbing unit.

For the full body harness, to attach the connecting and energy absorbing unit, use the attachment points marked with a capital 'A' only.

Always ensure you correctly set up the anchor device or structural anchor point used to connect the connecting and energy absorbing unit, and that you work with it in such a way as to reduce the risk of a fall, as well as the height of the fall. Always position the anchor device/anchor point above the workplace of the user. The shape and design of the anchor device/structural anchor point must prevent the equipment from being spontaneously disengaged. The permissible minimum static strength of the device/anchor point is 12 kN. It is recommended to use approved and marked, fixed structural anchor points complying with EN 795.

It is mandatory to check the required free space below the user at the work site before each use of the connecting and energy absorbing unit so that, in the event of a fall, the user does not collide with the ground or any other obstacle in the fall path. The length of free space required must be calculated with reference to the instructions manual of the equipment used.

There are a number of hazards that can affect the operation of the equipment, and appropriate precautions must be taken when using the equipment, and particularly when: - contact of the device line with sharp-edged

parts, - presence of any damage such as cuts, abrasion, corrosion, - exposure to weather conditions, - "pendulum effect" when falling, - presence of extreme temperatures, - presence of aggressive chemical agents, - contact with live electrical conductors.

Handle the PPE in a protected container (e.g. a moisture-resistant textile bag, plastic bag, steel or plastic boxes) to protect it from damage or exposure to moisture.

The equipment can be cleaned using methods that do not adversely affect the materials used in its manufacture. For textile products, use mild detergents designed for delicate fabrics; clean by hand or in a machine and rinse with water. For energy absorbers, wipe off dirt with a damp cloth only. It is forbidden to immerse energy absorbers in water. Plastic parts can only be cleaned with water. If the equipment gets wet during operation or cleaning, allow it to dry naturally, and protect it from heat sources located in direct vicinity. For products made of metals, some parts (springs, pins, hinges, etc.) can be lubricated regularly with a small amount of lubricant to ensure better performance.

Store the PPE in its package, in a well-ventilated place, and ensure it is protected from direct sunlight, ultraviolet degradation, moisture, sharp edges, extreme temperatures and corrosive substances or strong agents.

Using a device in combination with the personal protective equipment against falls from a height must follow the instructions manual of that device and the relevant standards.

Manufacturer: PROTEKT – Starorudzka 9 – 93-403 Łódź – Poland

This device meets the requirements of Regulation (EU) 2016/425 on personal protective equipment. EU Declaration of Conformity available at www.protekt.pl

Notified body issuing an EU type examination certificate in accordance with the PPE Regulation 2016/425: EU-Cert Sp. z o. o. (No. 2984), ul. Karola Szymanowskiego 12/U6, 80-280 Gdańsk, Poland.

Notified body supervising the production process: Apave SA (n°0082) – 6 Rue du Général Audran, 92412 COURBEVOIE cedex, France

OPERATION SHEET– It is the employer at the workplace where the equipment is used that is responsible for the entries in the operation sheet. The operation sheet should be completed before the equipment is first issued for use by the competent person responsible in the workplace for protective equipment. Information on factory periodic inspections, repairs and the reason for withdrawal of the equipment from use shall be posted by the competent person responsible at the workplace for periodic inspections of protective equipment. The service record should be kept for the entire service life of the equipment. Do not use personal protective equipment that does not have a completed operation sheet

PERIODIC INSPECTIONS AND SERVICING				
INSPECTION DATE	REASONS FOR REVIEW/REPAIR	DAMAGE FOUND, REPAIRS CARRIED OUT	NAME AND SIGNATURE OF THE RESPONSIBLE PERSON	DATE OF NEXT INSPECTION

MODEL AND TYPE OF EQUIPMENT	
SERIAL NUMBER	
PART NUMBER	
DATE OF MANUFACTURE	
DATE OF PURCHASE	
DATE OF ENTRY INTO SERVICE	
USERNAME	