

A



# PROTEKT®

CE 0082 EN 355:2002

EN ENERGY SHOCK ABSORBER WITH A ROPE

B

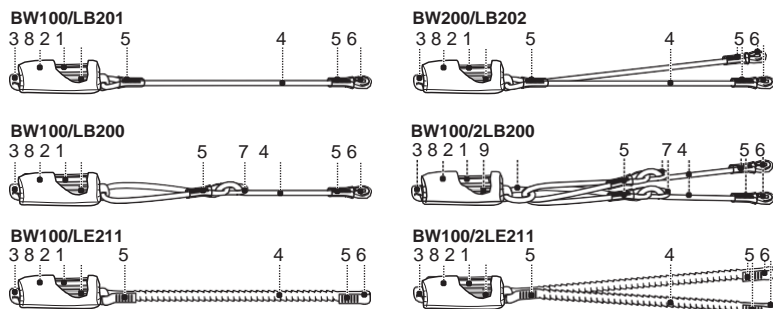

C

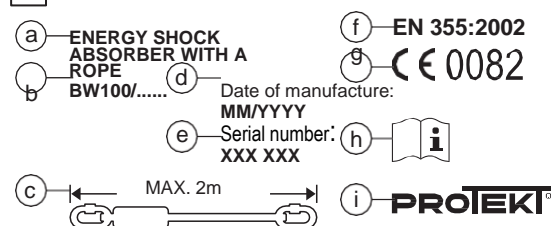

D

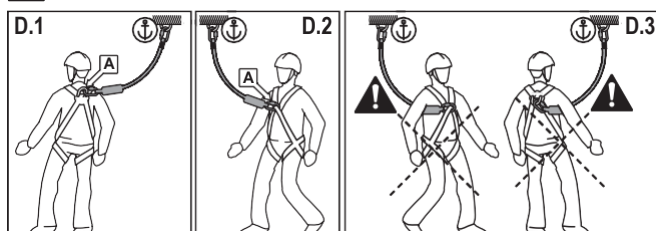

E

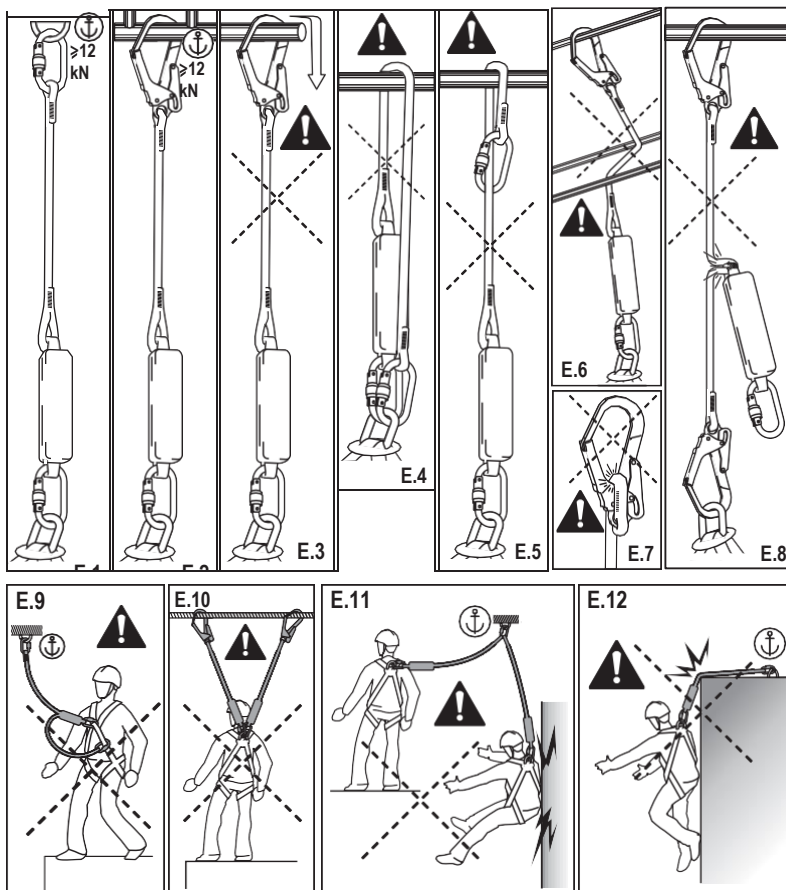

F

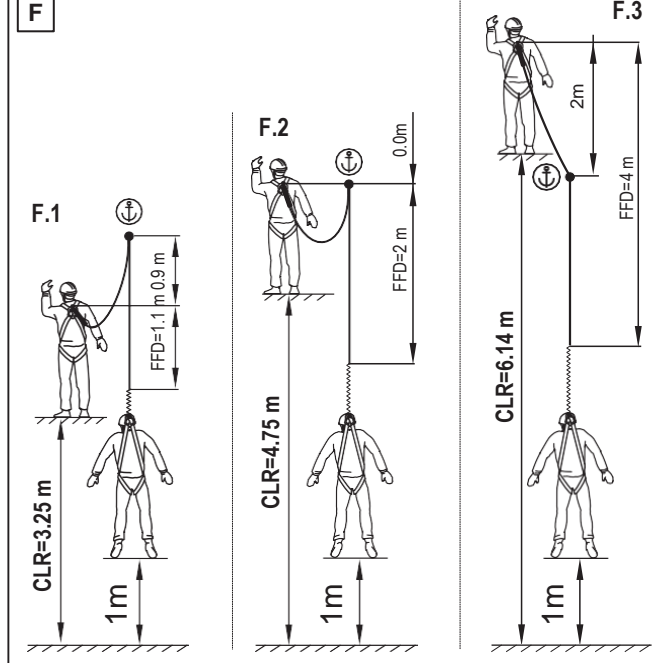

EN – ATTENTION: Read and understand this user manual before using this equipment. Work requiring the use of this equipment is dangerous. The user is obliged to follow this manual and is responsible for the correct use of the equipment. Misuse of the equipment can lead to injury or death. If you have any problems understanding this manual, please contact the equipment manufacturer.

#### A. DESCRIPTION

The energy absorber with a rope BW100 is a personal protective equipment against falls from height. The energy absorber is a device used to stop a fall when working at height and is a safety device for one person. The energy absorber with a rope complies with EN 355:2002 – "Personal protective equipment against falls from a height – Energy absorbers".

The BW 100 energy absorber is made of polyamide webbing. The energy absorber is integrated with a lanyard made of:

- braided core rope (polyamide core, aramid braid)  $\phi$  1.5 mm - part no. BW100/LB201, BW100/LB202;
- braided core rope (polyamide core, aramid braid)  $\phi$  1.5 mm with steel adjustment clip - part no. BW100/LB200, BW100/2LB200;

- aramid tape with a flexible core, 28 mm wide - part no. BW100/LE211, BW100/2LE211. With the heat shield, the energy absorber with a rope is heat resistant.

The maximum length of the shock-absorber with cable, terminations and connectors must not exceed 2 m.

#### B. DESCRIPTION OF COMPONENTS

1. Energy absorber
2. Equipment feature
3. Absorber's attachment loop
4. Safety lanyard
5. Seam
6. Safety lanyard's attachment loop
7. Adjustment buckle
8. Heat shield cover made of non-combustible fabric
9. Aluminium connecting link

#### C. DESCRIPTION OF MARKING

- a) device name

- b) part no.

- c) total maximum permitted rope length with energy absorber and connectors

- d) equipment production month/year

- e) serial number

- f) number: year of the European standard

- g) CE marking and the registration number of the notified body responsible for the device production process control

- h) note: read and understand the instructions manual before use

- i) manufacturer designation

#### D. ATTACHING THE BW100 ENERGY ABSORBER WITH A ROPE TO THE FULL BODY HARNESS

The energy absorber must be connected by means of a connector to the rear (D.1) or front (D.2) attachment point of the full body harness. Only use the points (buckles, loops) marked with a capital A. The full body harness must comply with EN 361. Connectors used with an energy absorber with rope must comply with EN 362. An energy absorber with rope should be attached to the full body harness in such a way that in the event of a fall it does not injure the person being secured (D.3).

#### E. CONNECTING THE BW100 energy absorber WITH A ROPE TO AN ANCHOR POINT

The energy absorber rope must be connected by means of certified EN 362 connectors to an EN 795 compliant anchorage point with a minimum strength of 12 kN (E.1, E.2). The anchor point shape and design shall ensure that PFAE is permanently connected and cannot accidentally detach (E.3). Do not tie the rope by wrapping it around an anchor point (E.4) or by wrapping the rope in the form of a clamping loop (E.5). The rope must not be allowed to intertwine between the various components of the structure (E.6). Note the incorrect position of the rope inside the connector (E.7). On shock absorbers with a double rope (BW100/LB202, BW100/2LB200, BW100/2LE211), do not connect one safety rope to the user's harness and the other rope to the anchor point (E.8). Do not attach the free end of the double rope connected to the energy absorber back to the full body harness (E.9). Do not attach two energy absorbers to the harness in parallel with a rope (E.10) Moving horizontally in relation to the anchor point involves the risk of hitting obstacles during a swing fall (E.11), as well as the risk of falling over an edge (E.12).

#### F. MINIMUM REQUIRED DISTANCE BELOW THE USER FEET

When using a BW100 energy absorber with a rope, the required minimum distance below the user's feet (CLR) must be ensured to avoid collision with the structure or the ground during fall arrest. The minimum required clear distance depends on the position of the anchor point

of the energy absorber with rope and the associated free fall length (FFD) during fall arrest and is respectively:  
 F.1. Anchor point located 0.90 m above harness attachment point - free fall distance FFD=1.10 m - required distance below user's feet **CLR is 3.25 m**.  
 F.2. Anchor point located at the level of the harness anchor point - free fall distance FFD=2.00 m - required distance below the user's feet **CLR is 4.75 m**.  
 F.3 Anchor point located below the user's feet - free fall distance FFD=4.00 m - the necessary required distance below the user's feet **CLR is 6.14 m**.

**G. PERIODIC REVIEWS**

At least after every 12 months of operation – starting from the date of first use – a periodic inspection of the fall arrester shall be performed.  
 The periodic inspection shall only be carried out by a competent individual who is experienced and trained in the periodic inspection of PPE.  
 The operating conditions may affect the frequency of periodic maintenance, which can be carried out more frequently than every 12 month of operation. Each periodic inspection shall be recorded in the fall arrester's service log.

**H. MAXIMUM SERVICE LIFE**

The operating life of the equipment is 10 years from the production date.

**NOTE:** The maximum service life depends on the duty and operating environment. Operation of the fall arrester in harsh conditions, with frequent exposure to water, sharp edges, extreme temperatures or corrosive chemicals may lead to premature mandatory removal from service, even after a single use only.

**I. DECOMMISSIONING**

The fall arrester shall be removed service immediately and disposed of (be irreversibly destroyed) if it has arrested a fall, failed to pass a periodic inspection, or its reliability raises any concerns.

**J. MAIN PRINCIPLES OF PERSONAL PROTECTIVE EQUIPMENT (PPE) AGAINST FALLS FROM A HEIGHT**

- PPE shall only be used by personnel trained in its operation.
- PPE shall not be used by individuals with any health condition that may affect their safety during regular use or in an emergency.
- Prepare an emergency response plan that can be implemented at work when needed.
- While suspended using PPE (e.g. after arresting a fall), mind that there can be injury from suspension.
- To avoid adverse effects of suspension, ensure that an appropriate emergency rescue plan is ready for use. The use of positioning straps is recommended.
- Never attempt to modify the fall arrester without prior written consent from the manufacturer.
- Any repair of the fall arrester shall only be carried out by its manufacturer or its authorised representative.
- PPE shall not be used in any way other than its intended use.
- PPE is a type of personal equipment and shall be operated by a single dedicated user only.
- Before using the fall arrester, verify that all components of the gear which forms the fall arrest system interact correctly. Periodically inspect the joints and fitting of PPE to avoid accidental release or detachment.
- Do not use PPE kits in which the performance of any component is inhibited by performance of any other component.
- Before each use of PPE, do its thorough visual inspection to verify that the fall arrester is fit for service and its operating test is passed OK.
- During the pre-use visual inspection, verify all components of PPE with particular attention to all evidence of damage, excessive wear, corrosion, abrasion, cuts, or malfunctions. Inspect these components with extreme care:
  - in full body harnesses, waist belts, and positioning belts: shackles, adjustment parts, anchor points (shackles/tethers), straps, stitching, and loops;
  - in fall arrest energy absorbers: tether loops, lanyards, stitching, casing, and connectors;
  - in textile fibre life lines and anchor lines: lines, loops, thimbles, connectors, adjustment parts and knots;
  - In steel cable life lines and anchor lines: cables, cable wires, end clamps, thimbles, connectors, and adjustment parts;
  - cable/lanyard-operated retractable type fall arresters: proper performance of the winding and locking gears, the casing, the energy absorber, and the connector;
  - guided type fall arresters: casing, proper running on the anchor line, locking gear performance, sheaves, bolts, rivets, connectors, and the energy absorber;
  - metal hardware (connectors, snap hooks, and shackles): load-carrying body, rivet fasteners, main latch, and the locking gear performance.
- At least once a year, every 12 months of operation, PPE requires removal from service for a thorough periodic inspection. The periodic inspection shall be carried out by a competent, experienced and qualified individual.

- The inspection can also be carried out by the PPE manufacturer or its authorised representative.
- in certain cases, if PPE has a complex and sophisticated design like retractable type fall arresters, periodic inspections shall only be done out by the manufacturer or its authorised representative. Following the periodic inspection, the next periodic inspection date shall be identified.
  - Regular periodic inspections are critical to the condition of PPE and the safety of its user, which depends on uncompromised performance and durability of PPE.
  - During the periodic inspection, check the legibility of all PPE markings and labels (which apply to the PPE unit in question). Do not use PPE with illegible markings.
  - It is critical to the safety of the PPE user that if PPE is sold outside its country of origin, the PPE supplier shall provide it with the instructions for use and maintenance and the procedures of periodic inspection and repair in the official language of the country in which the PPE will be used.
  - PPE shall be removed from service immediately and disposed of (or other procedures in the instructions for use shall be followed) if it has arrested a fall.
  - EN 361 compliant safety full body harnesses are the only acceptable body support equipment for PPE.
  - PPE shall only be connected to the safety full body harness tether points (buckles or loops) market with an upper-case "A".
  - The PPE anchor point shall be of a stable construction and in a location which minimises the risk of fall and the length of free fall. The PPE anchor point shall be above the PPE user's workstation. The anchor point shape and design shall ensure that PPE is permanently connected and cannot accidentally detach. The minimum load capacity of the PPE anchor point shall be 12 kN. Operation of certified and marked PPE anchor points that comply with EN 795 is recommended.
  - It is mandatory to verify the clearance underneath the workstation where personal protective equipment against falls from a height will be used to avoid hitting obstacles or a surface below while a fall is being arrested.
  - The size of the required clearance under the workstation shall be verified with reference to the instructions for use of the PPE to be used.
  - When operating PPE, inspect it regularly, paying special attention to all hazardous events and damage affecting the PPE performance and the safety of the PPE user, in particular: the snagging or sliding of life and anchor lines over sharp edges, pendulum-effect falls, live voltage conduction, all types of damage – cuts, wearing, corrosion, etc. – effects of extreme temperatures, adverse effect of climate conditions, and effects of chemicals.
  - Carry/transport PPE in a packaging which protects it from damage and moisture, e.g. waterproof bags or in steel or plastic cases.
  - PPE shall be cleaned with tools and methods which do not compromise the materials of the equipment. For textile fibre materials (lanyards, belts, straps, and ropes), use gentle detergents intended for textiles. Cleaning can be done by hand or by machine washing. Rinse thoroughly afterwards. Fall arrest energy absorbers shall only be cleaned with a cloth damp with water. Do not immerse the energy absorber in water. Plastic parts shall be cleaned with water only. The PPE soaked or wet from cleaning or use shall be thoroughly dried in open air and away from sources of heat. Metal parts and gear (springs, hinges, latches, etc.) can be lubricated periodically with a light film of the lubricant to improve their performance.
  - Store PPE loosely packed, in well-ventilated, dry areas, and away from sunlight, UV radiation, dust, sharp objects, extreme temperatures and corrosive chemicals.
  - All PPE components shall conform to their instructions for use and the prevailing standards: EN 353-1, EN 353-2, EN 354, EN 355, EN 360 – for fall arrest systems; EN 362 – for connectors; EN341, EN1496, EN1497, EN1498 – for emergency rescue/recovery equipment; EN 361 – for full body harnesses; EN 813 – for waist belts; EN 358 – for work positioning systems; EN 795 – for anchor point equipment.

Manufacturer:  
 PROTEKT - Starorudzka 9 - 93-403 Łódź - Poland  
 tel. +4842 6802083 - fax: +4842 6802093  
 Declaration of conformity is available at [www.protekt.pl](http://www.protekt.pl)

Notified body of the EU type testing certificate issuer per Regulation (UE) 2016/425: EU-Cert Sp. z o. o. (No. 2984), ul. Karola Szymanowskiego 12/U6, 80-280 Gdańsk, Poland.

Production control notified body: Apave Exploitation France SAS (n°0082) - 6 Rue du Général Audran - 92412 COURBEVOIE cedex - France

**OPERATION SHEET** – It is the employer at the workplace where the equipment is used that is responsible for the entries in the operation sheet. The operation sheet should be completed before the equipment is first issued for use by the competent person responsible in the workplace for protective equipment. Information on factory periodic inspections, repairs and the reason for withdrawal of the equipment from use shall be posted by the competent person responsible at the workplace for periodic inspections of protective equipment. The service record should be kept for the entire service life of the equipment. Do not use personal protective equipment that does not have a completed operation sheet.

PERIODIC INSPECTIONS AND SERVICING				
INSPECTION DATE	REASONS FOR REVIEW/REPAIR	DAMAGE FOUND, REPAIRS CARRIED OUT	NAME AND SIGNATURE OF THE RESPONSIBLE PERSON	DATE OF NEXT INSPECTI ON

MODEL AND TYPE OF EQUIPMENT	
SERIAL NUMBER	
PART NUMBER	
DATE OF MANUFACTURE	
DATE OF PURCHASE	
DATE OF ENTRY INTO SERVICE	
USERNAME	